

# SPEED CONTROL OF DC MOTOR USING CASCADED H-BRIDGE MULTILEVEL INVERTER

R.K ARVIND SHRIRAM\*, A.L KUMARAPPAN\*\*

\*(Assistant Professor, Department of Electrical and Electronics, Meenakshi Sundararajan Engineering College, Chennai

Email: rsriram1987@gmail.com)

\*\* (Professor and Head, Department of Electrical and Electronics, Sri Sai Ram Engineering College, Chennai

Email: hod.eee@sairam.edu.in)

**ABSTRACT-** A hybrid cascaded multilevel inverter for interfacing with renewable energy resources is developed. The objective of this research is to propose an alternative topology of hybrid cascaded multilevel inverter applications. The modified PWM technique is also developed to reduce switching losses. Also, the proposed topology can reduce the number of required power switches compared to a traditional cascaded multilevel inverter. PSIM (PowerSim) and Simulink/MATLAB are used to simulate the circuit operation and control signal. The 3-kW prototype is developed. The reduced switching losses of the proposed multilevel inverter are also discussed. The results show that this alternative topology can be applied for high power applications.

## I. INTRODUCTION

The cascade inverter has drawn great interest due to the great demand of medium-voltage high-power inverters. These multilevel inverters can extend rated inverter voltage and power by increasing the number of voltage levels. They can also increase equivalent switching frequency without the increase of actual switching frequency, thus reducing ripple component of inverter output voltage and electromagnetic interference effects.

A multilevel converter has several advantages over a conventional two-level converter that uses high switching frequency pulse width modulation (PWM). The attractive features of a multilevel converter can be briefly summarized as follows.

**1. Staircase waveform quality:** Multilevel converters not only can generate the output voltages with very low distortion, but also can

reduce the dv/dt stresses; therefore electromagnetic compatibility (EMC) problems can be reduced.

**2. Common-mode (CM) voltage:** Multilevel converters produce smaller CM voltage; therefore, the stress in the bearings of a motor connected to a multilevel motor drive can be reduced. Furthermore, CM voltage can be eliminated by using advanced modulation strategies.

**3. Input current:** Multilevel converters can draw input current with low distortion.

**4. Switching frequency:** Multilevel converters can operate at both fundamental switching frequency and high switching frequency PWM. It should be noted that lower switching frequency usually means lower switching loss and higher efficiency.

Multilevel converter has disadvantage that greater number of power semiconductor switches needed. Although lower voltage rated switches can be utilized in a multilevel converter, each switch

**requires a related gate drive circuit. This may cause the overall system to be more expensive and complex.**

**Abundant modulation techniques and control paradigms have been developed for multilevel converters such as Sinusoidal Pulse Width Modulation (SPWM), Selective Harmonic Elimination (SHE-PWM), Space Vector Modulation (SVM), and others. In this**

IJSER

thesis Sinusoidal Pulse Width Modulation (SPWM) and Space vector pulse width modulation (SVPWM) techniques were used.

The block diagram of improved Z-source inverter based on the hardware kit model is as shown in the figure 3.1 It consists of

Switch Status	State	Pole Voltage
$S_1=ON, S_2=ON$ $S_1=OFF, S_2=OFF$	$S=+ve$	$V_{a0}=V_{dc}/2$
$S_1=OFF, S_2=ON$ $S_1=ON, S_2=OFF$	$S=0$	$V_{a0}=0$
$S_1=OFF, S_2=OFF$ $S_1=ON, S_2=ON$	$S=-ve$	$V_{a0}=-V_{dc}/2$

Table-1.1. Switching states in one leg of the three-level diode clamped inverter

II. BLOCK DIAGRAM FOR SEVEN LEVEL INVERTER

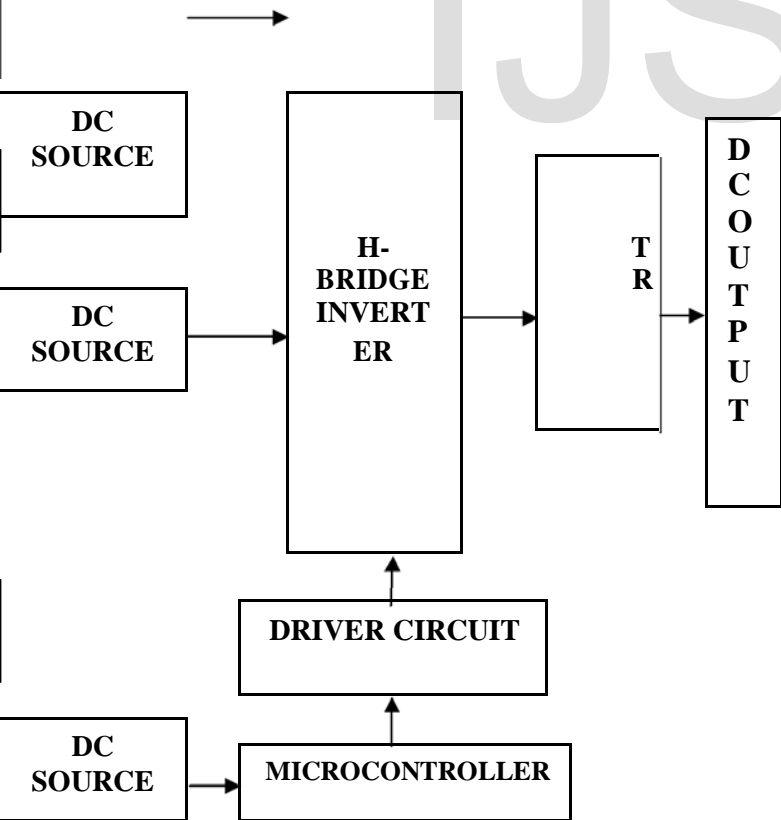

Figure1.1

1. AC supply input voltage of 220v-240v.
2. A step down transformer which is used to step down or decrease the input AC supply to 12v.
3. Bridge rectifier is used to convert AC supply to DC supply and also regulate DC supply to 5v.
4. PIC microcontroller is used to generate Pulse Width Modulation (PWM) wave.
5. Driver circuit is used to turn ON or turn OFF power transistor or MOSFET by giving proper gate signals to respective switches on three legs of inverter circuit.
6. Another DC supply or DC link is fed to improved Z-source inverter circuit which will perform buck or boost operation.
7. The driver circuit signal and signal from Z-source circuit is given to three phase inverter circuit which converts DC supply to AC supply and then fed to three phase loads.

#### OUTPUT WAVEFORM OF PIC MICROCONTROLLER

The output of the PIC microcontroller will be Pulse Width Modulation (PWM) wave. This wave is produced by comparing the oscillating wave and the sine wave. Oscillator produces the oscillating wave and the sine wave is produced by the program in the PIC microchip. The output PWM signal waveform is as shown in figure 5.1

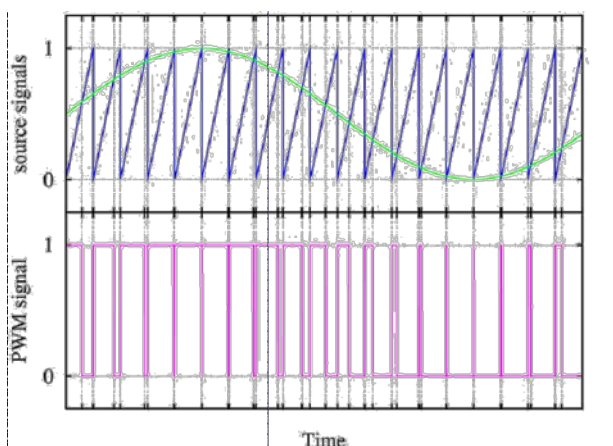
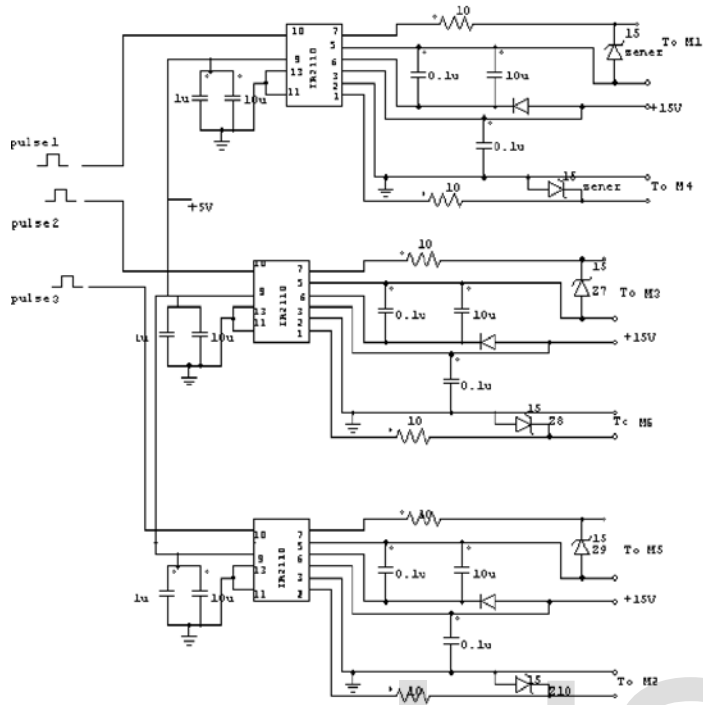

Fig 1.2 PIC output waveform

**DRIVER CIRCUIT**



**Fig 1.3 Driver Circuit**

In electronics, driver is an electrical circuit or other electronic component used to control another circuit or other component, such as a power MOSFET or high-power transistor. The term is used, for example, for a specialized computer chip that controls the high-power transistors in DC-to-DC voltage converters. The Driver circuit diagram is as shown in the Fig 5.1. In this three driver circuit are used for switching operation of six MOSFET. Each driver circuit controls switching operation for two MOSFET. For this purpose IR2110 IC is used. The IR2110 is a high voltage, high speed power MOSFET driver with independent high and low side referenced output channels. The Pin diagram of IR2110 is shown in below Figure

**SIMULATION RESULTS**

Simulation is the discipline of designing a model of an actual or theoretical physical system, executing the model on a digital computer, and analyzing the execution

output. There are many methods of modeling systems which do not involve simulation but which involve the solution of a closed-form system (such as a system of linear equations).

Simulation is often essential in the following cases: 1) the model is very complex with many variables and interacting components; 2) the underlying variables relationships are nonlinear; 3) the model output is to be visual as in a 3D computer animation.

### SEVEN LEVEL INVERTER

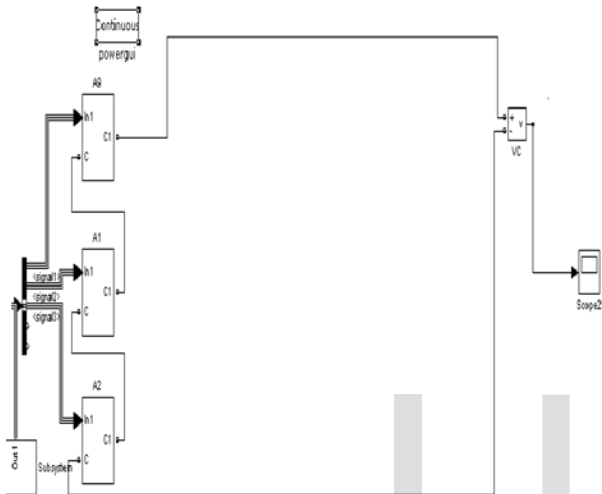

Fig 1.4 Seven Level Inverter

### H-BRIDGE INVERTER

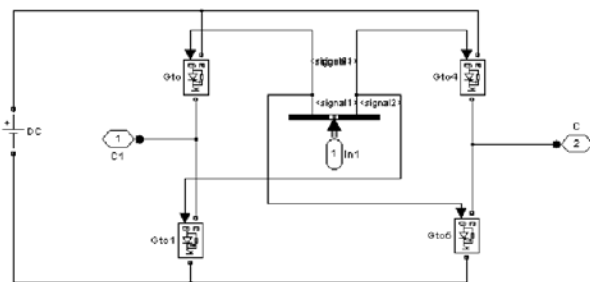
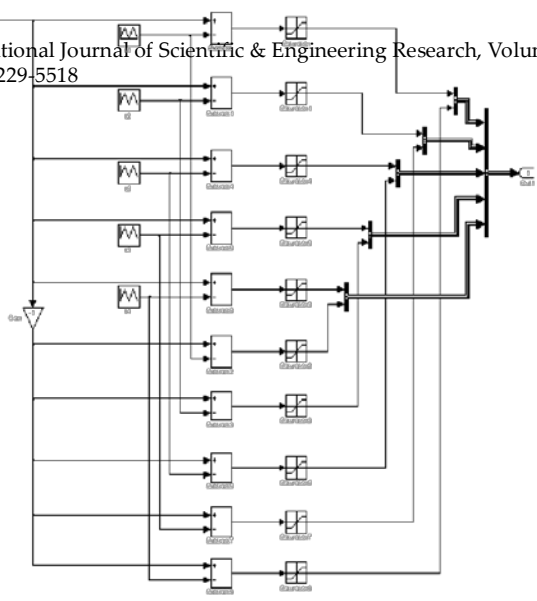

Fig 1.5 H-Bridge Inverter

### PWM GENERATION CIRCUIT



### SIMULATED SEVEN STEP MULTILEVEL OUTPUT

Fig 1.6 Simulated Seven Step Multilevel Output

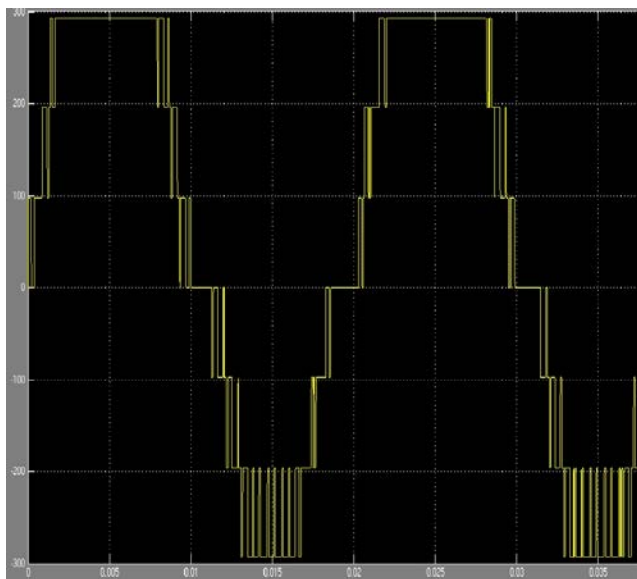

## CONCLUSION

The feasibility of a cascaded multilevel inverter is to control the speed of a dc motor, it presents the following features and advantages:

- 1) continuous control of the series injected voltage
- 2) low harmonic distortion of the injected voltage
- 3) very low switching frequency and low

switching losses.

## REFERENCES

1. Z. Du, L. M. Tolbert, and J. N. Chiasson, "Active harmonic elimination for multilevel converters," *IEEE Trans. Power Electron.*, vol. 21, no. 2, pp. 459–469, Mar. 2006.
2. L. Ben-Brahim and S. Tadakuma, "A novel multilevel carrier-based PWM-control method for GTO inverter in low index modulation

region," *IEEE Trans. Ind. Appl.*, vol. 42, no. 1, pp. 121–127, Jan./Feb. 2006.

3. J. S. Lai, J. Rodriguez, J. Lai, and F. Peng, "Multilevel inverters: A survey of topologies, controls and applications," *IEEE Trans. Ind. Appl.*, vol. 49, no. 4, pp. 724–738, Aug. 2002.
4. J. Rodriguez, J. S. Lai and F. Z. Peng, "Multilevel inverters: Survey of topologies, controls, and applications," *IEEE Trans. Ind. Applicat.*, vol. 49, no. 4, pp. 724-738, Aug. 2002.
5. Beser, E.; Camur, S.; Arifoglu, B.; Beser, E.K. , "Design and application of a novel structure and topology for multilevel inverter," in Proc. IEEE SPEEDAM, Tenerife, Spain, 2008, pp. 969 – 974.
6. R.H. Baker, "High-Voltage Converter Circuit," U.S. Patent Number 4,203,151, May 1980.
7. S. Mekhilef and M. N. Abdul Kadir "Voltage control of three-stage hybrid multilevel inverter using vector transformation" *IEEE Trans. Power Electron.*, vol. 25, no. 10, pp 2599-2606, Oct. 2010.
8. L.M. Tolbert, F. Z. Peng, T. G. Habetler, "Multilevel PWM Methods at Low Modulation Indices," *IEEE Trans. Power Electron.*, vol. 15, no. 4, pp. 719-725, July 2000.